

# UTS 700 ONEMAN

## Instruction Manual

### Mobile Access Tower

#### 3T - Through the trap method

### Instruction Manual

This Assembly Guide is intended to provide you with step-by-step instructions on how to erect your Mobile Access Tower (MAT) with ease and safety, using the 3T (through the trap) method.

You should read and understand all notes and diagrams, including the parts list for each height, before commencing assembly. Personnel should be qualified or competent to erect this tower. Please consult the PASMA's code of practice for full information on the use of Mobile Access Towers.

Remember to do a risk assessment of the area where the tower is to be used before commencing erection.

This instruction manual shall be available on the location of use of the mobile access and working tower.

This mobile access and working tower shall only be used according to this manual without any modification.

Mobile access and working towers must only be used in accordance with national regulations.



UTS SALES & REPAIR LTD

Manufactured to: BSEN1004-1:2020 CLASS 3 4/4 XXXD H2

Instruction Manual EN 1004-2 en

T&RGETMARK<sup>®</sup>  
CERTIFIED

BS EN 1004-1:2020  
BS EN 1004-2:2021

TM1008  
testandresearch.org



# HEALTH AND SAFETY WARNINGS

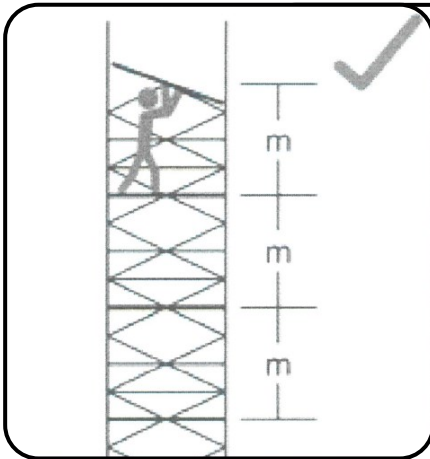

Maximum height between platforms of 2.2m

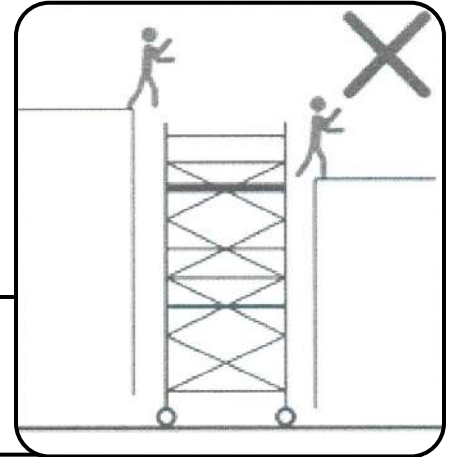

Do not use the tower as a form of access or exit

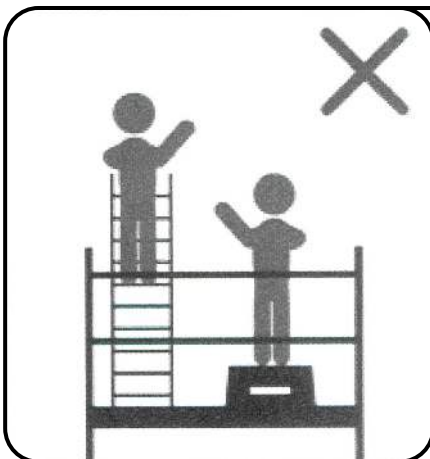

Do not use ladders, boxes or and other objects to gain additional height.

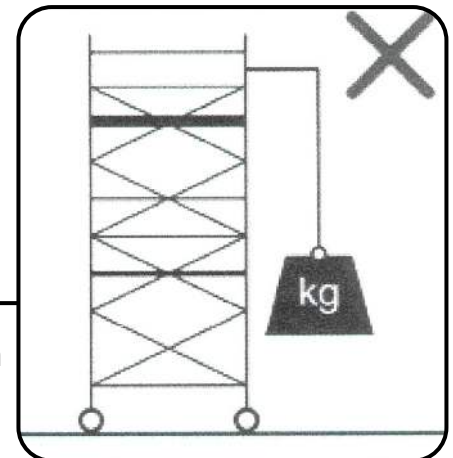

Do not lift heavy objects from the tower

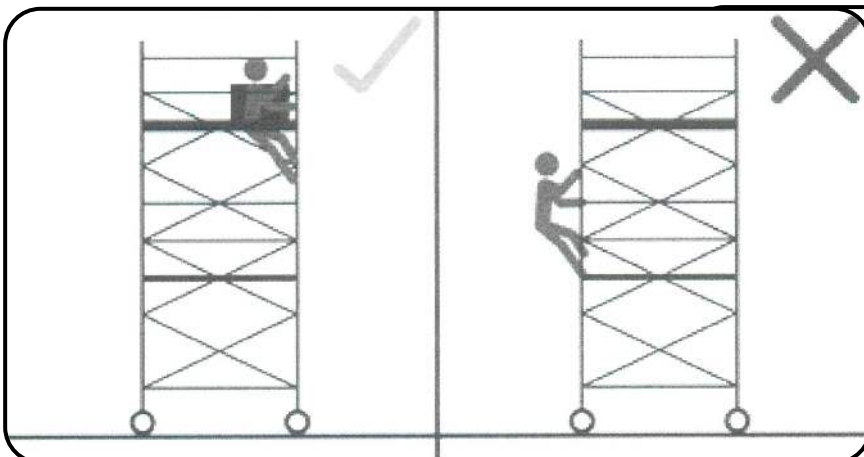

Do not climb outside of the tower, only climb up inside the tower.

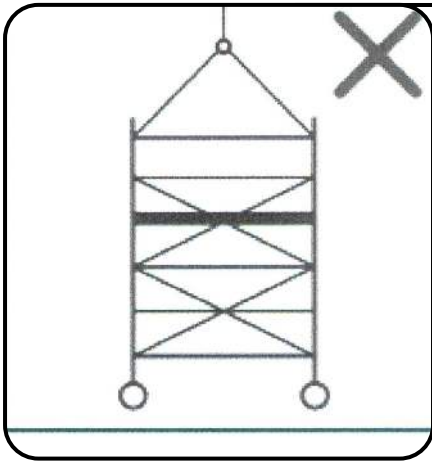

Do not suspend or lift the tower

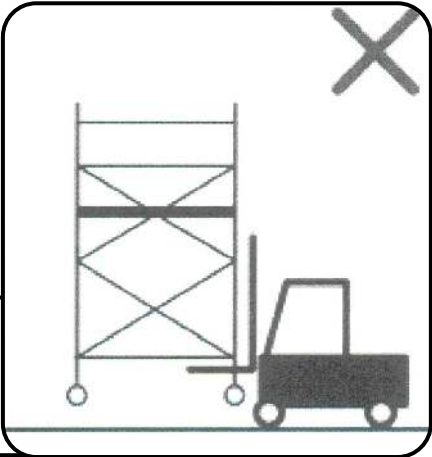

Do not lift the tower with mechanical equipment

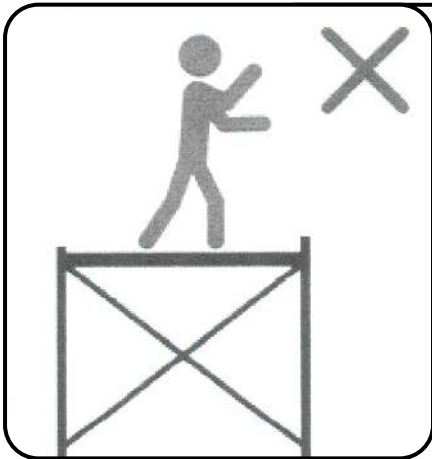

Do not stand up on an unguarded platform

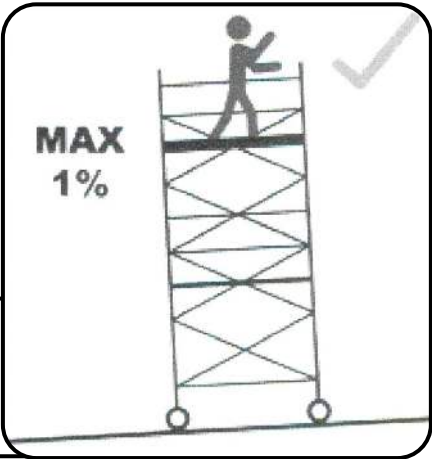

Maximum inclination for working = 1%

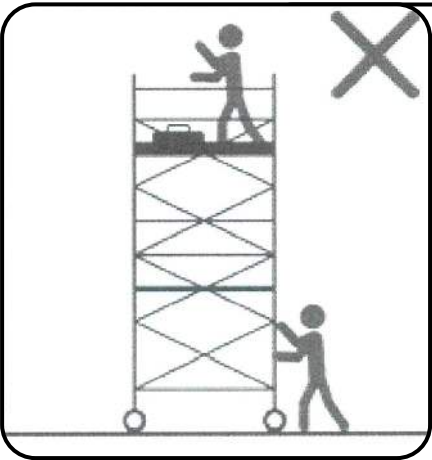

Do not move the tower with material or people on it

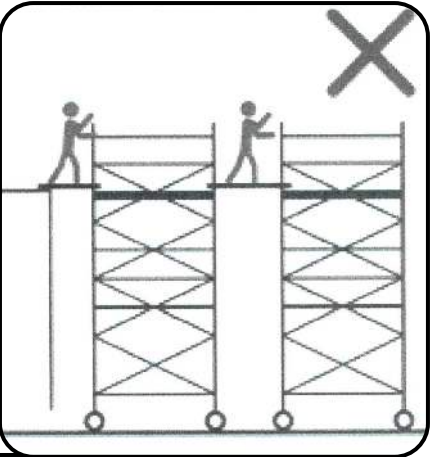

Do not bridge between towers or other structures

# UTS 700 ONEMAN

## Instruction Manual

### Mobile Access Tower

<b>Contents</b>	<b>Page</b>
Description	5
Safety Notes & Fittings	5
Inspection Care and Maintenance	7
Components and Weights	10
Assembly	11
Dismantling	19
Configurations and Weights	20
Risk Assessment Form	21

UTS SALES & REPAIRS LTD  
UNIT 1A CANTERBURY INDUSTRIAL PARK,  
ISLAND ROAD,  
HERSDEN,  
CANTERBURY,  
KENT,  
CT3 4HQ  
TEL:01227860085  
WWW.TOWERSANDPODIUMS.CO.UK

# Description, Safety Notes & Fittings

## Description

The UTS 700 ONEMAN tower is manufactured to BSEN1004-1:2020 CLASS 3 8/12 XXXD H2 and TARGET MARKED. The TARGET MARK is a recognised symbol that reassures the user that the product is certified to BSI stated standards.

The UTS 700 ONEMAN tower is a lightweight aluminium industrial tower designed for use by one person. It gives a safe and secure work area at a range of heights indoors and outdoors to enable maintenance and installation work. Designed for lone working it is ideal for a small maintenance crew or traveling engineer, ensuring that working at height is as safe as possible.

- Instructions for erection and use must to be followed carefully.
- The UTS 700 ONEMAN has a maximum working platform height of 4.2 meters indoors or outdoors.
- The maximum permissible load on the UTS 700 ONEMAN tower is 750kgs and evenly distributed on each platform is 275kgs. This must not be exceeded over the working height platform, not including rest platforms.
- Maximum of 1 working platform per tower.
- Maximum of 1 person per working platform.
- Damaged or incorrect components shall not be used.

## Risk analysis

Proper risk analysis of our towers reveals that all components are integral to the safety of the tower once assembled, and that while assembling is the greatest period of risk. If the user follows the instructions set out in this manual it will contribute to the reduction of risk of injury, this along with the PASMA training recommended in the manual should be enough to significantly reduce the risk possibility down to improbable if not impossible.

The components have been designed in such a way that they can be assembled in an order that allows for minimal risk to occur, such as the assembly tool allowing for easier movement of components up the tower while assembling.

The addition of instructional stickers on the OMT Braces reminds the user to tighten the locks on the clamps before ascending the tower. Instructions in the manual and training courses are very clear about how to access the tower and the correct method is displayed on the tower as a reminder, but ensuring all components and materials are of the highest standard, means we can be confident that even if misuse was to occur, we can be confident that the components would be able to still prevent injury.

It is important to limit the risk of all tasks especially when working at height. It is the user's responsibility to complete a risk assessment then use that to reduce the risk associated with the task (a blank one can be found at the back of this manual). Once the full risk assessment is completed and all hazards have been identified and controlled it is down to the user to decide if there is still too much risk in which case do not erect or use tower and look for alternative access arrangements.

## Safety Notes

### **ERECTION & DISMANTLING - THE 3T(through the trap) METHOD**

Towers should be erected following a safe method of work, there are two approved methods recommended by 'Prefabricated Access Suppliers & Manufacturers Association' (PASMA) in co-operation with the Health and Safety Executive (HSE) & the "working at height regulations 2005"

The method used for erecting and dismantling the UTS 700 ONEMAN tower is the 3T METHOD (through the trap). This method ensures the operators erecting the tower position themselves in the trapdoor of the platform to add or remove horizontal guardrail braces for the level above the platform.

### **NEVER STAND ON AN UNGUARDED PLATFORM.**

Before assembly or erection of this Mobile Access Tower (MAT) please ensure that:

- A risk assessment has been done and all safety equipment is on site.
- The ground conditions will take the working loads of MAT as specified.
- Always check that the MAT is vertical, (Level, slope, uneven ground etc.) if levelling is required make sure you adjust legs , in line with instructions (use spirit level).
- Beware of (overhead) obstructions – live wires, electrical apparatus or moving parts of machinery or other.
- Wind conditions are within limits as specified. (Refer to page 7)
- Do not use boxes, ladders, or other devices on the platform to gain additional height.
- If in doubt DO NOT ERECT.

- Check that all components are on site and that they are in good working order before use (refer to the components and quantities shown at each stage). Auxiliary equipment and safety equipment. (ropes, etc)
- All platforms MUST have horizontal guardrails fitted.
- The tower should always be accessed from the inside using the rungs of the end frames.
- Never climb up the outside.
- Use of Scaffolding tags or similar is required during use to ensure all correct safety information is on display; **MUST INCLUDE:**
  - The name and contact details of the responsible person.
  - If the tower is ready for application or not.
  - The load class and the uniformly distributed load.
  - If the mobile access and working tower is intended for indoors use only.
  - The date of assembly.
- Do not use the guardrail braces as a rung or step.
- It is recommended that at least 1 persons erect this tower.
- The assembled tower should not be used as a means to enter or exit other structures, e.g. as a stair tower.
- Beware of horizontal forces (e.g., when using power tools on an adjacent structure), which could generate instability or overturning of the tower.
- Maximum distance between platforms is 2.25m, maximum distance to the first platform is 3.4m.
- Maximum horizontal force 20kgs.
- Mobile access and working towers are not designed to be sheeted
- The tower height used should be appropriate for the working height, e.g. within 2 meters above the platform
- User training courses cannot be a substitute for instruction manuals but only complement them.
- Only the original UTS components specified in the manual shall be used.
- Mobile access and working towers designed in accordance with BS EN 1004-1:2020 are not anchor points for personal fall arrest equipment.
- Working is only permitted on a platform with a complete side protection including guardrails and toe boards.
- Mobile access and working towers are not designed to be used as edge protection.

## STABILISERS & BALLAST

Stabilisers or outriggers and ballast shall always be fitted when specified. When using the MAT externally stabilisers must be fitted. Should ballast be required, a platform should be positioned on the lowest rung and the weights should be firmly attached to it and evenly distributed. For advice on ballast contact your supplier.

## MOVING THE TOWER AND LEAVING IT UNATTENDED

- Adjust the stabilisers to provide ground clearance.
- Unlock the castor wheels.
- Move with manual force only, and only from the base.
- Beware of (overhead) obstructions – live wires, hanging apparatus or other objects.
- Do not move with people or material on the tower.
- Do not move the assembled MAT if wind speeds exceed a moderate breeze. Relock the castors and readjust the stabilisers once in the new position.
- When moving the tower over uneven or sloping ground remove all tools.
- Do not move the assembled tower if over 4 meters high.
- Mobile access and working towers shall only be moved on a flat and solid ground without obstacles and not on a slope of more than 10mm/1m
- It is recommended that towers should be tied to a solid structure, when left unattended.
- Recheck that the MAT is vertical or needs readjustment of legs before ascending. (Using spirit level)
- Relock Caster brakes and extend stabilisers after moving before ascending.
- Check to make sure all components are there before using after moving or leaving unattended.
- Recheck environment before using tower after it has been moved or left unattended.

## LIFTING OF INDIVIDUAL TOWER COMPONENTS

Raising and lowering components, tools and/or materials by rope should be conducted within the tower base (i.e. within the area bounded by the stabilisers). Ensure that the safe working load of the supporting decks and the tower structure is not exceeded.

Check for environmental changes before every use. (i.e.: all weather conditions) Refer to wind effects section.

## LIFTING OF EQUIPMENT

Tools and other equipment should be hauled up by a person on the platform using rope or similar, through the trapdoor of the platform or within the tower footprint.

Please see footprint guide on page 19.

Safe working loads of platform and tower not to be exceeded.

## TIES

When ties are required, they should be in accordance with table 17 of BS 5973:1990 and table 24 of BS 5975:1982. Always tie to a solid structure.

The tie frequency should be at 4 meter intervals or less vertically.

## CHECK LIST, INSPECTION CARE AND MAINTENANCE FOR MOBILE ACCESS TOWERS

- All components should be inspected before use to ensure that they are not damaged or broken, particularly the welds.
- ANY damage to ANY part particularly tubular members, castors, platform decking MUST be replaced.
- Adjustable leg threads should be cleaned and lightly oiled.
- All locking claws should be cleaned, and the locking mechanism checked for operation.
- When storing your MAT, please ensure that all components are neatly stored and not left lying around where they could be stood on or damaged.
- When transporting the MAT always tie the components down so that they do not move around and get damaged.
- Should the tower be left unattended it should be tied to a suitable structure and on reuse ALWAYS check that the tower is vertical and safe before ascending correct and complete structure.
- The MAT is not designed to be lifted or suspended as a complete structure.
- Always keep this instruction manual safe.
- Broken, damaged or incorrect components must never be used. The equipment shall be quarantined and assessed for replacement repair or destruction.

## WIND EFFECTS

- Beware of high, gusty, or moderate breeze conditions in exposed areas. It is recommended that in wind speeds over a Moderate Breeze (see Beaufort Scale below) that work on the tower is stopped and reassessed. If the wind becomes a Strong Breeze, (see Beaufort Scale below) the tower should be tied to a rigid structure. If the wind is likely to reach Gale Force (see Beaufort Scale below) or over, work should be stopped, and the tower should be dismantled.
- Beware of tunnelling effect caused by open ended buildings, uncladded buildings and building corners.

Wind	Beaufort Scale 10 Meters above ground	Force	Speed in m.p.h.	Speed in knots
Moderate Breeze	Raises dust and loose paper, small branches move.	4	13–18	11–16
Strong Breeze	Large branches in motion, telegraph wires whistle.	6	25–31	22–27
Gale Force	Walking is difficult, twigs break off trees.	8	39–46	34–40

## Tools

- The use of a spirit Level is required when levelling the tower.
- Rope may be required to hoist components or tools to higher work platforms.

## FITTING ADJUSTABLE LEGS

Take the adjustable leg assembly complete with its castors, make sure that all the adjusting nuts are positioned down at the castor and slide them into the vertical tube, turn the base unit the right way up and with the aid of a spirit level placed on the platform, the adjusting nuts can be used to level the structure. (and not to gain additional height).



## LOCKING CASTORS

Castor wheels should be pointed outwards at approximately 45 degrees.

## LOCKING CLIPS

Fit the locking clips as shown in the diagram opposite.

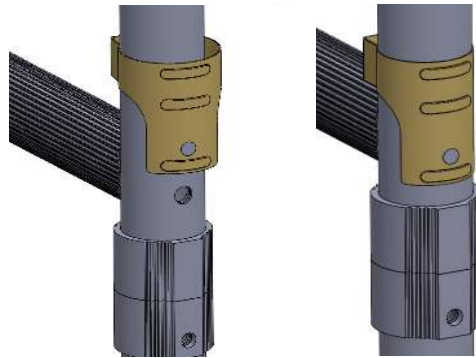

## CORRECT FITTING OF HORIZONTAL BRACING

THE CORRECT FITTING OF HORIZONTAL BRACING IS IMPORTANT.

The diagrams opposite illustrate the CORRECT brace positions.

REMEMBER: Always fit braces DOWNWARD or from the inside facing OUTWARD – BUT NEVER INWARD

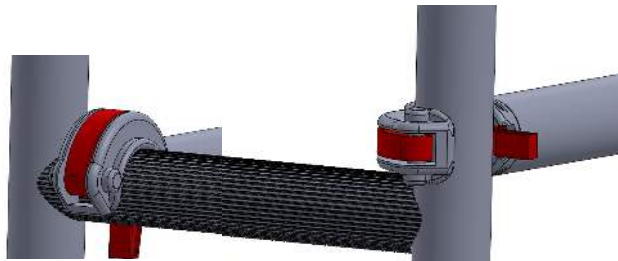

## AGR CLAMP LOCKING

Hook over AGR clamp

Unscrew palm wheel

Then rotate bottom block into locked position.

Retighten palm wheel.

**ALWAYS ENSURE BOTH BOTTOM AGR CLAMPS ARE LOCKED BEFORE CLIMBING UP TOWER TO LOCK TOP AGR CLAMPS.**

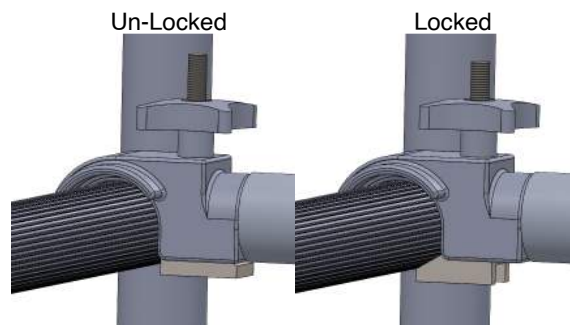

## FITTING STABILISERS

To attach stabilisers clamps, undo palm wheel all the way, fit one side of clamp to vertical frame, then rotate second side of clamp to fit vertical frame and tighten palm wheel.

Attach a stabilisers in configurations as shown on pg19 for maximum stability in different situations.

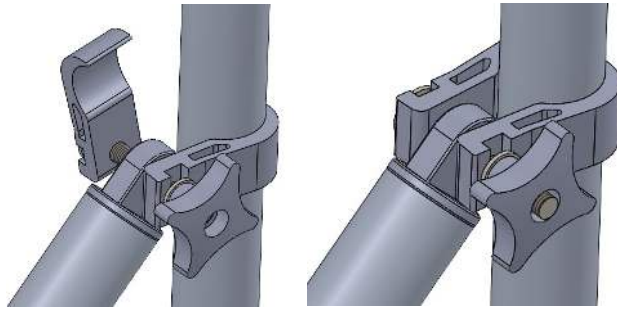

## EXTENDING STABILISERS

On the S3 stabiliser use the telescopic leg for adjustment on uneven ground.

Flex retaining clip, displayed in red, to then be able to remove retaining pin. Leg can now extend, line up desired hole on inner leg with outer holes, reinsert retaining pin and rehook retaining clip to ensure it cannot come undone.

Make sure that all stabilisers are firmly in contact with the ground when using the structure.



## FITTING TOE-BOARDS

### 1 piece folding toe board

Unfold out over platform, hook bottom edges over sides of platform.

Ensure short ends of toe boards have hooked over both ends of the platform, hook bottom edge down between platform hook and frame.

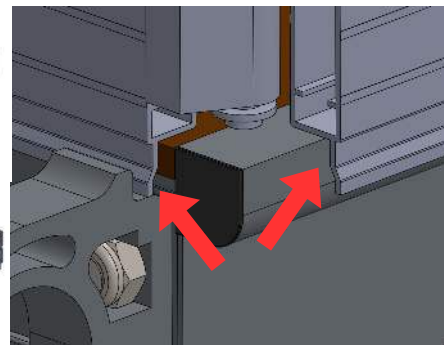

## Assembly tool

To enable One Man Assembly, hook the tool onto either a brace frame or an end frame partial up the tower.

Then hook components onto the tool from lower down and retrieve them from higher platforms

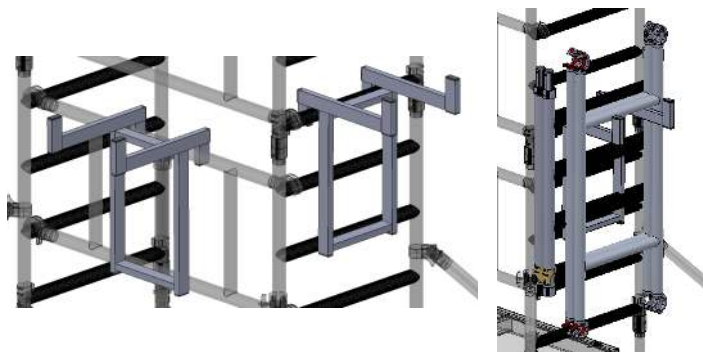

## BRACE CLAMP LOCKING

Ensure that the brace clamp is locked as shown.

Always make sure the brace is not clamped too close to the weld as indicated by the arrow on the drawing on the right.

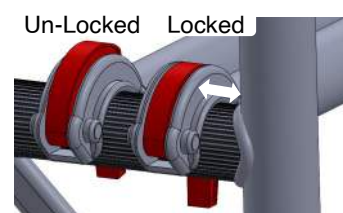

# Identifying Components and Their Weights

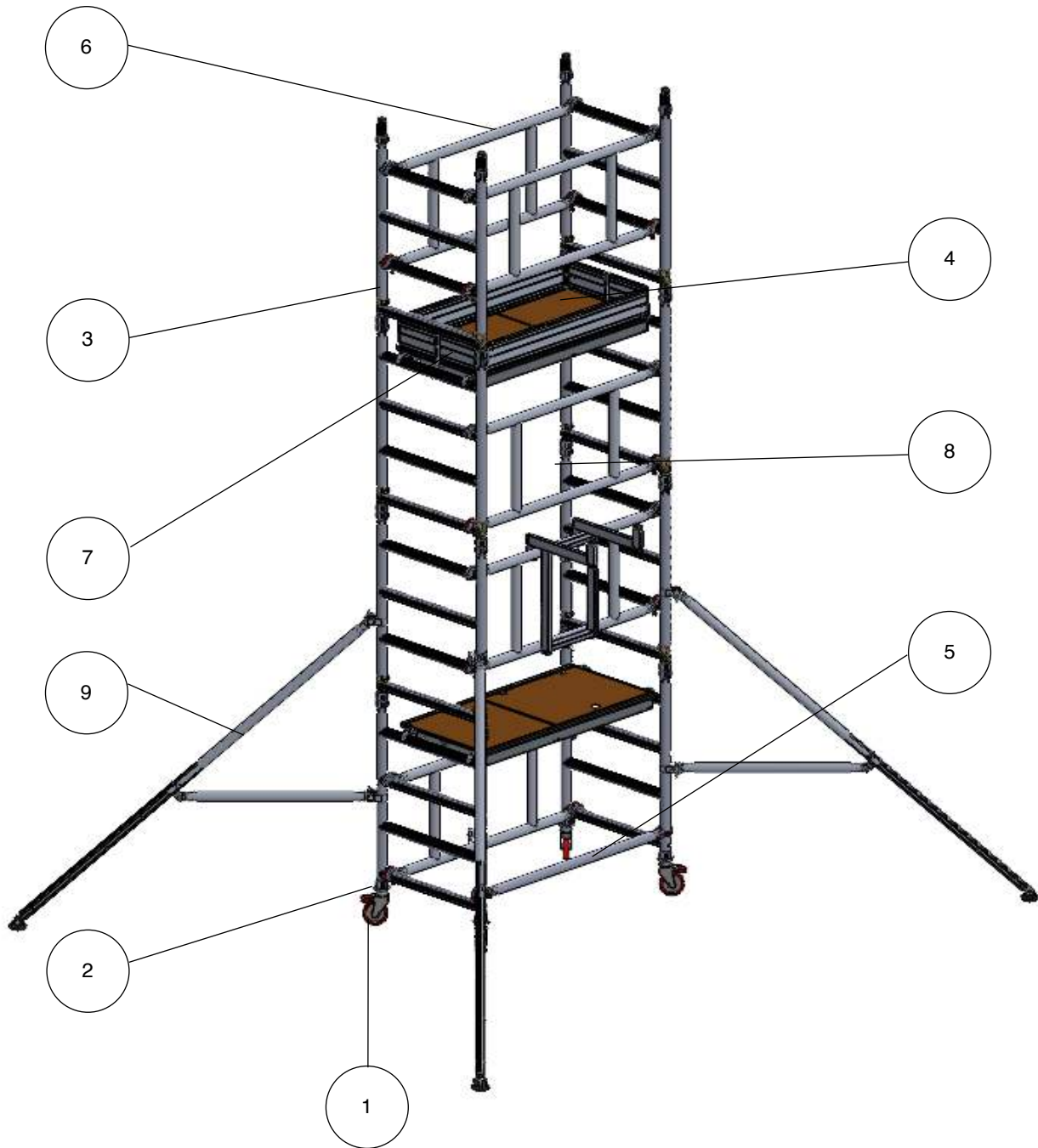

## Tower Components and Approx. Weights

Item	Description	Weight (Kg)	Item	Description	Weight (Kg)
1	150mm Locking Caster	3.4	6	1.3m OMT Brace	6
2	Adjustable Leg 500mm	1.1	7	Complete Toe Board Set	12
3	1m 4 Rung Frame	5.6	8	OMT Hanging Bracket	1
4	1.3m Trapdoor Platform	9.1	9	S3 Stabiliser	5.9
5	1.3m Horizontal Brace	1.9			

# Assembly Procedure

UTS recommends that a minimum of two people is required for the assembly of the UTS 700 ONEMAN tower. Only climb the tower from the inside using the end rungs.

1. Insert adjustable leg assembly (with castors or base plates) into the base of a rung end frame, then repeat this with the other rung end frame.  
Lock all castor wheels

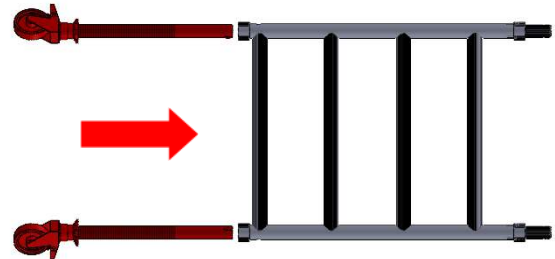

2. Attach one horizontal brace (red) to the first rung of the end frame, claws facing downwards.  
This frame will now be self-supporting.

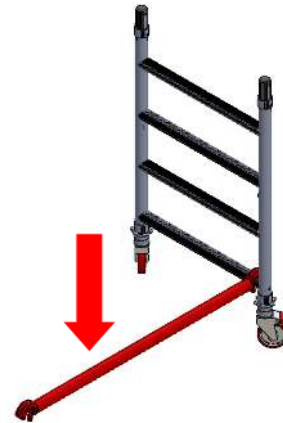

3. Position the frame as shown. Connect other end of horizontal brace (red) to the first rung on the new end.

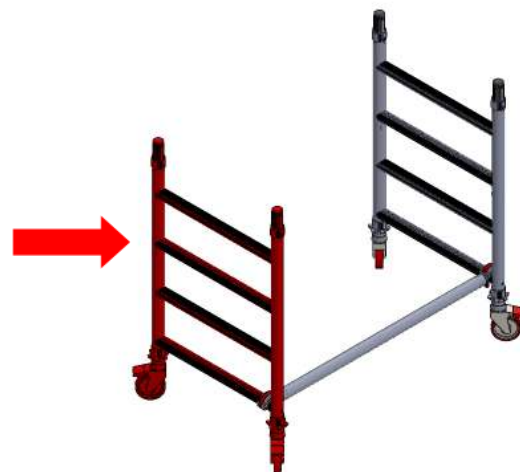

## PLEASE TAKE NOTE

Never place the platform on the guardrail frame

Always climb from the inside of the frame – never the outside. When working on the platform never overreach

The end frames should provide a firm hand hold.

## 1.2/3.2m Configuration Assembly Instructions.

1-3. Start with steps 1—3 on page 11

Fit OMT Brace to 1st and 3rd rung of tower, ensure bottom clamps are locked (refer to page 8)

4. Insert 4 rung sides onto each end of the tower, ensure they clip in (refer to page 8)

Fit OMT Brace to 6th and 8th rungs of towers, ensure bottom clamps are locked.

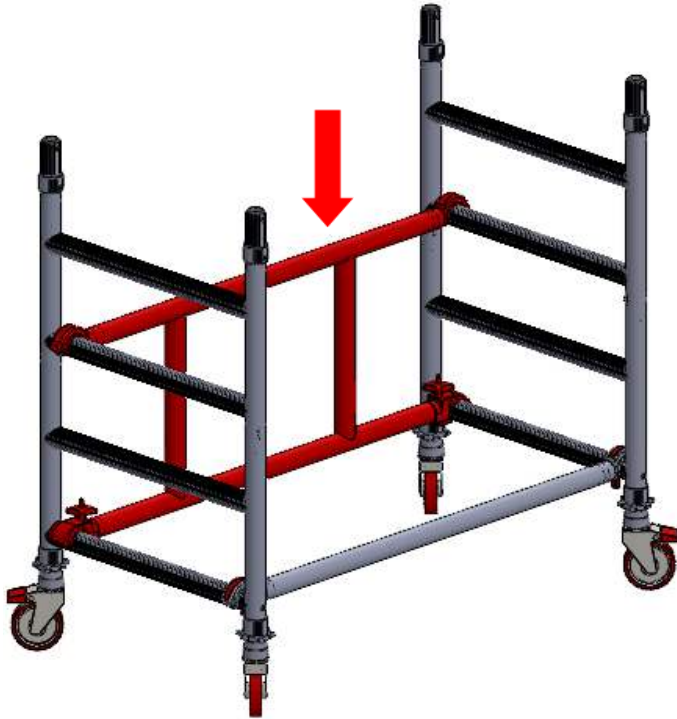

Note: this is a good time to use the spirit level and adjust the legs to get the tower flat.

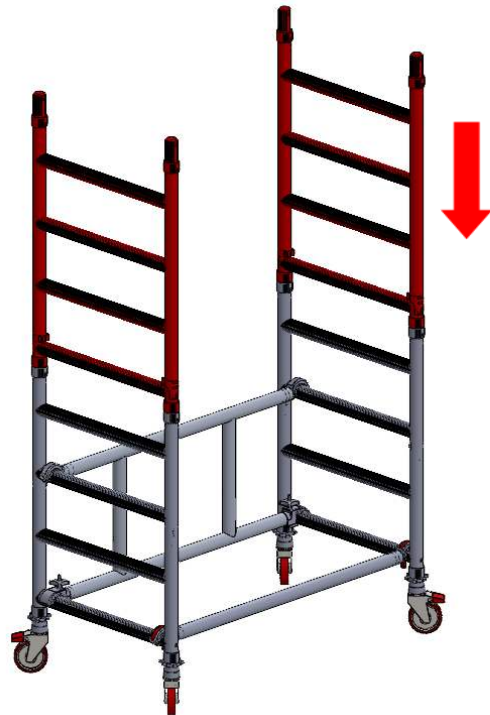

Fit a trap door platform to 4th rung of the tower, engage the wind locks.

5.

If completing at 1.2m fit toe boards to the working platform. (see instructions on page 9)

If not continue to page 14.

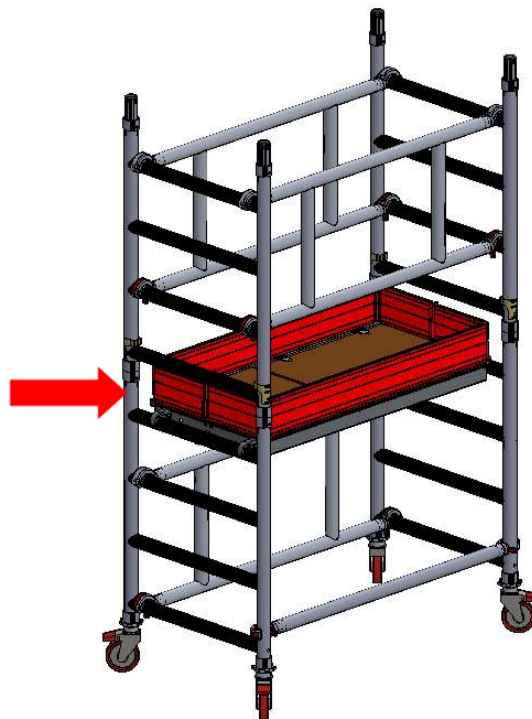

Attach stabilisers, ensure connected and tightened.

6.

Connect two of the 4 rung frames together using the clips, then climb the tower on the inside using the rungs of the end frames. Fit these double 4 rung ends to each end of the tower as shown.

Fit a OMT Brace to the 9th and 11th rungs of the tower, then hang an assembly bracket from it to allow the easy moving of components to higher levels.

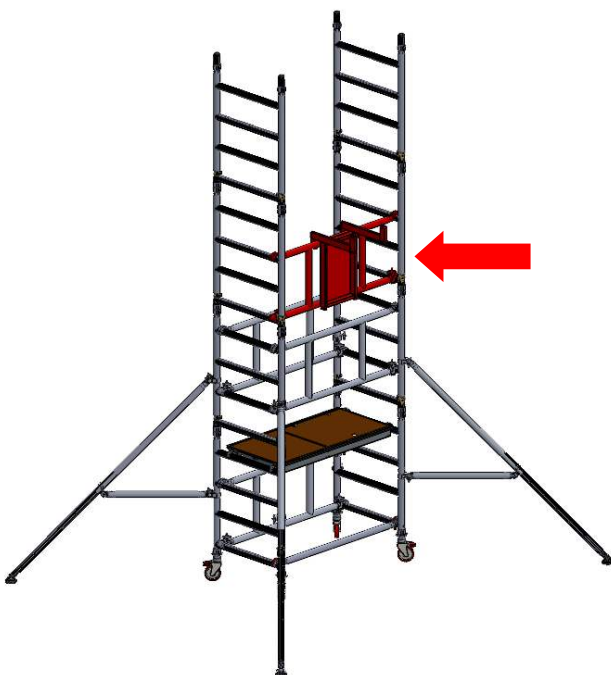
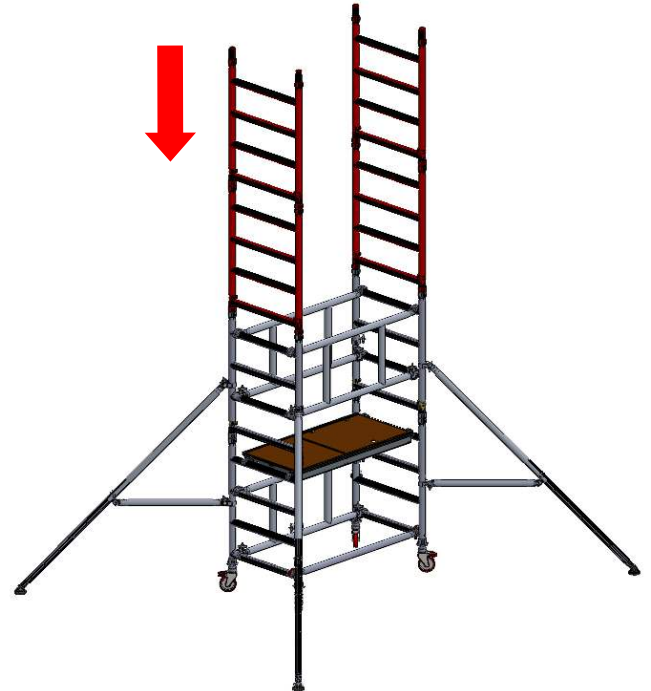
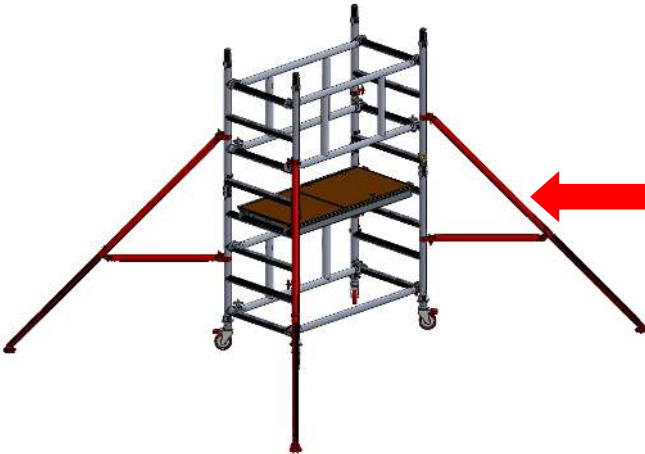

Add a platform on the 12th rung, lock wind locks,

7.

From a seated position within the trap door of the platform fit a OMT Braces to the 14th and 16th rungs of the tower, then ensure the bottom clamps are locked.

Fit toe boards to the working platform. (see instructions on page 9)

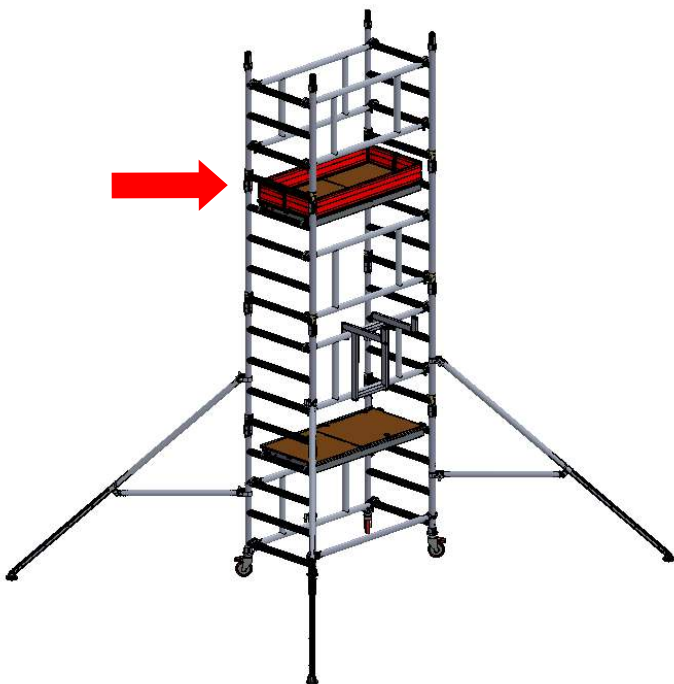
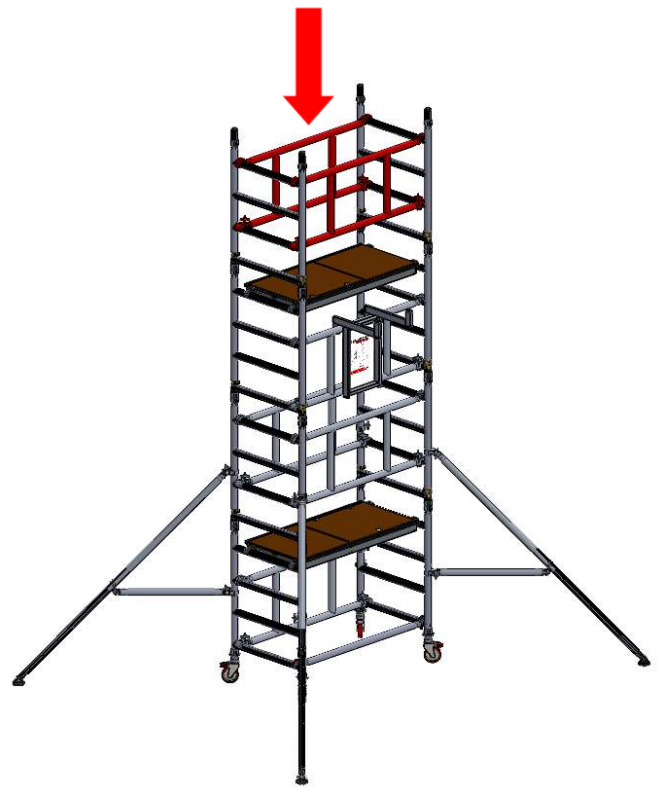
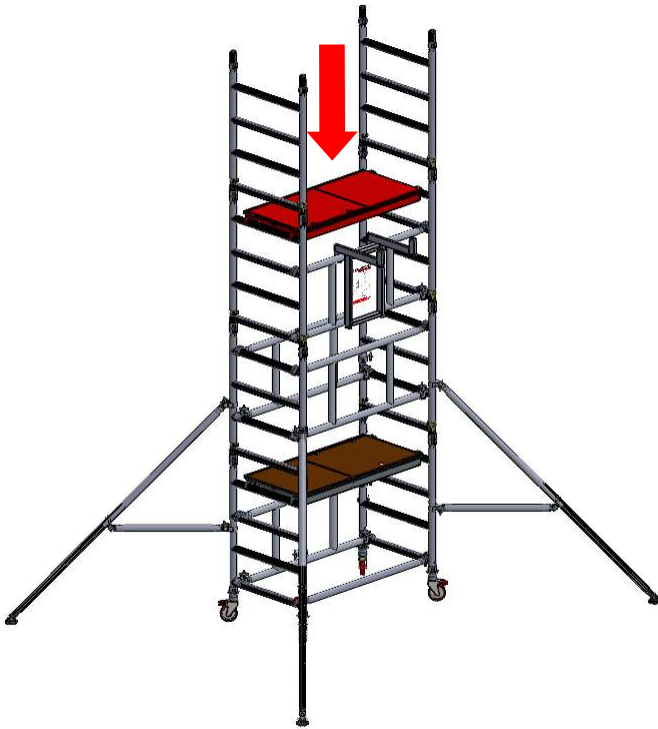

## 2.2/4.2m Configuration Assembly Instructions.

1-3. Start with steps 1—3 on page 11

Fit OMT Brace to 2nd and 4th rung of tower, ensure bottom clamps are locked (refer to page 8)

Connect two of the 4 rung frames together using the clips, then climb the tower on the inside using the rungs of the end frames. Insert these onto each end of the tower, ensure they clip in (refer to page 8)

4.

Fit a OMT Brace to the 5th and 7th rungs of the tower, then hang an assembly bracket from it to allow the easy moving of components to higher levels.

Fit a trap door platform to 8th rung of the tower, engage the wind locks.

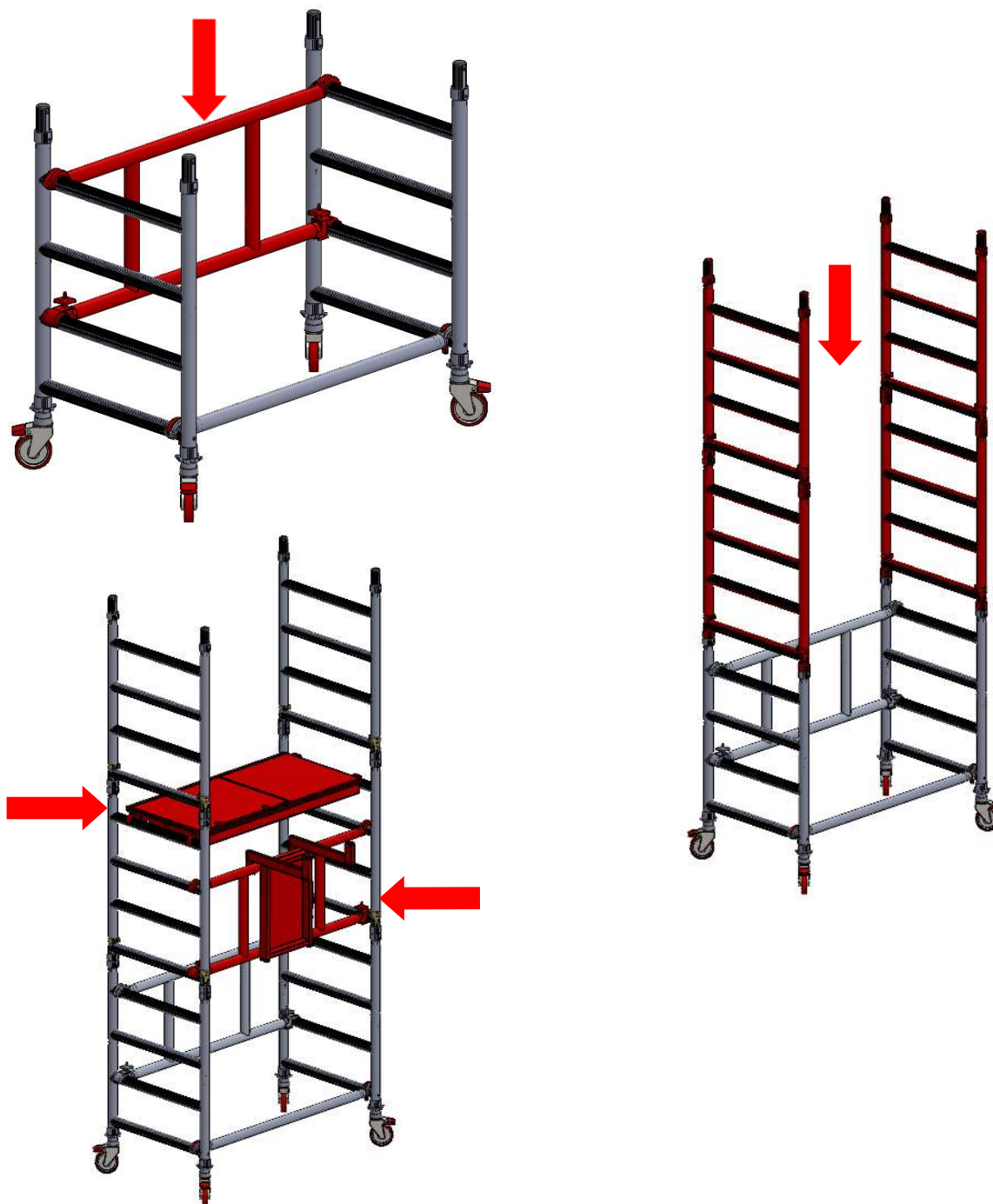

Attach stabilisers, ensure connected and tightened.

From a seated position within the trap door of the platform fit a OMT Braces to the 14th and 16th rungs of the tower, then ensure the bottom clamps are locked.

5.

If completing at 2.2m fit toe boards to the working platform. (see instructions on page 9)

If not continue to page 18.

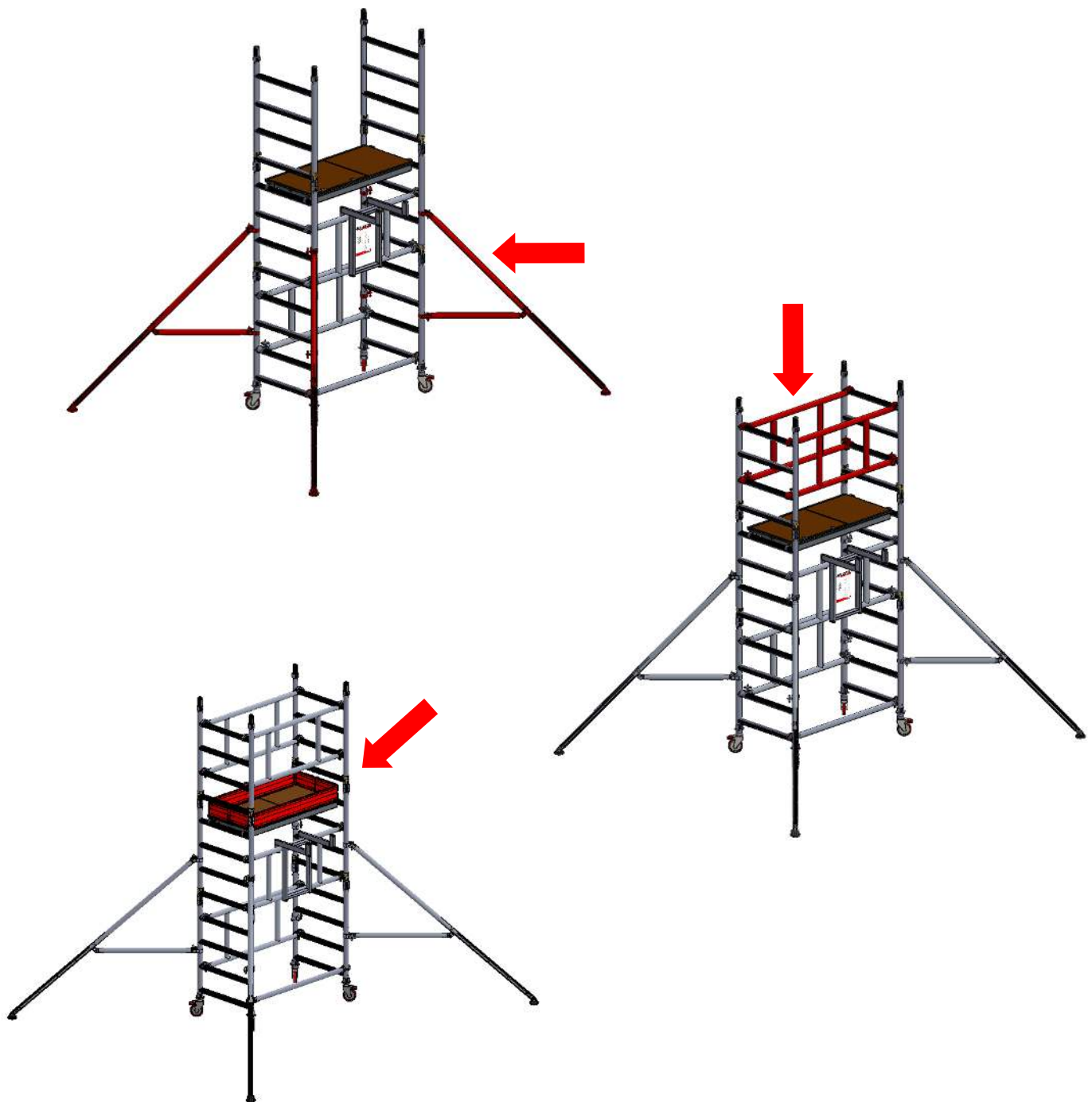

Connect two of the 4 rung frames together using the clips, then climb the tower on the inside using the rungs of the end frames. Fit these double 4 rung ends to each end of the tower as shown.

5.

Add a platform on the 16th rung, lock wind locks,

Fit a OMT Brace to the 13th and 15th rungs of the tower, then hang an assembly bracket from it to all the easy moving of components to higher levels.

From a seated position within the trap door of the platform fit a OMT Braces to the 18th and 20th rungs of the tower, then ensure the bottom clamps are locked.

Fit toe boards to the working platform. (see instructions on page 9)

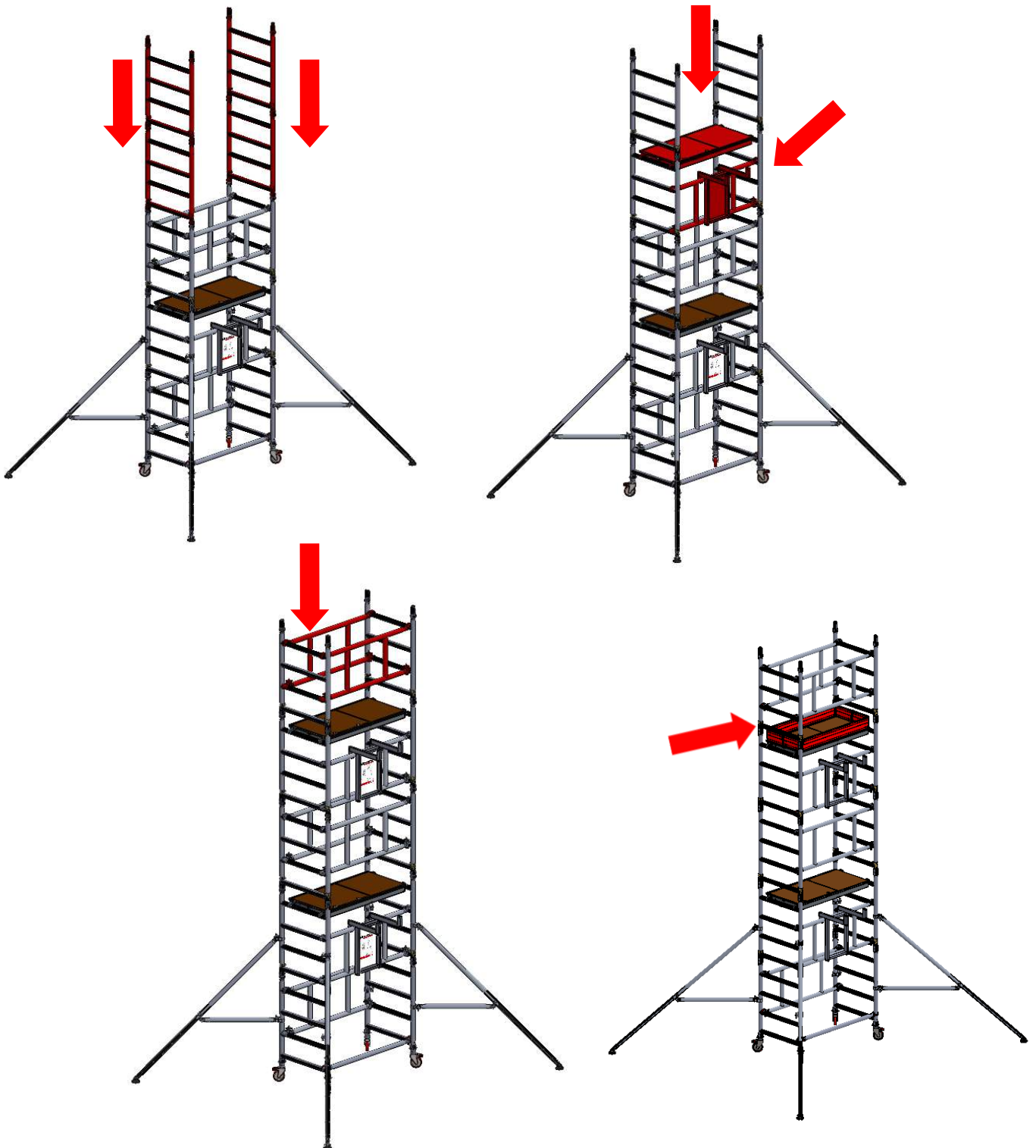

# Dismantling

The dismantling procedure should follow the assembly steps in reverse order, take particular attention about the removal of guardrails and platforms.

You should ensure that you are standing in a safe position and always protected by guardrails NEVER remove diagonal braces or stabilisers prematurely.

After removing the toe-boards the operator disengages the horizontal guardrail brace clamps furthest from the trap door, horizontal guardrail braces are then removed with the operator positioned through the trap door before descending to the lower level, from where the upper platform and extensions/guardrail frames can be removed.

## NOTES:

DO NOT OVER-REACH and NEVER DROP COMPONENTS when dismantling always lower them to the ground.

## STABILISERS

Attach one stabiliser to each corner of tower at approx. 45 degrees. The bottom clamp should be fitted as low as possible, refer to the diagram opposite. Ensure that all four rubber feet are in contact with the ground and that the clamps are secured. Position stabilisers as shown in the diagrams.

When moving the tower lift each telescopic leg just clear of the ground, unlock castors ensuring the area is firm and clear of all obstructions both on the ground and above.

After moving check all castors are firmly on the ground and locked, and that the tower is vertical. Re-position stabilisers as above.

When using tower near a wall or in a corner, the stabiliser layout needs to be adjusted to accommodate.

As shown in the diagram if against a wall 2 stabilisers should be made parallel to the wall and the others should remain at 45°.

If being used in a corner, the closed corner stabiliser can be removed and the 2 near walls should be made parallel with the open corner stabiliser remaining at 45°.

STABILISERS—S3

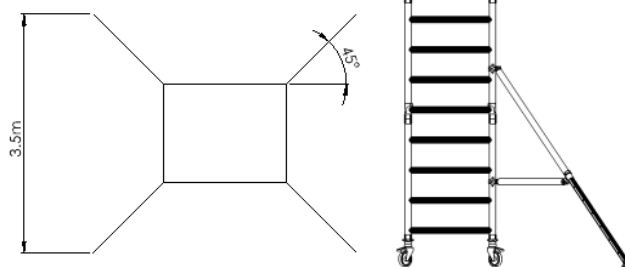

Static Stabiliser maximum platform height of 4.2m

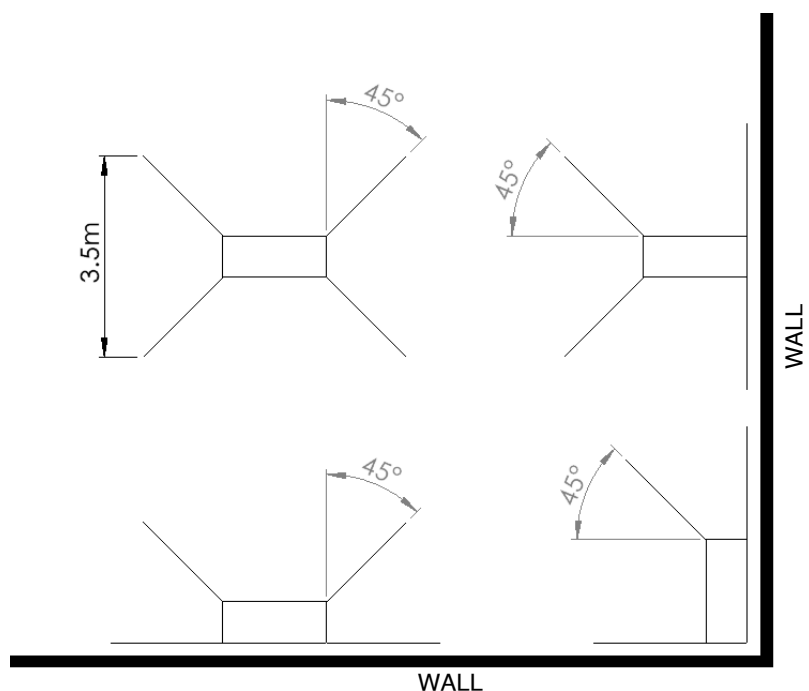

# 700 ONEMAN

Configurations to BSEN 1004:-1:2020

Working Height (M)  
Platform Height

Description	3.2	4.2	5.2	6.2
	1.2	2.2	3.2	4.2
150mm Locking Caster	4	4	4	4
Adjustable Leg 500mm	4	4	4	4
1m 4 Rung Frame	4	6	8	10
1.3m Trapdoor Platform	1	1	2	2
1.3m Horizontal Brace	1	1	1	1
1.3m OMT Brace	3	4	6	7
Complete Toe Board Set	1	1	1	1
OMT Assembly Tool	0	1	1	2
Instruction Manual	1	1	1	1
S3 Stabiliser		4	4	4
Approx. Tower Shelf weight (Kgs) 1.8m	75.4	117.2	149.5	167.7

## Notes:



# Notes:

**UTS SALES & REPAIRS LTD**  
UNIT 1A CANTERBURY INDUSTRIAL PARK,  
ISLAND ROAD,  
HERSDEN,  
CANTERBURY,  
KENT,  
CT3 4HQ  
TEL: 01227 860085  
WWW.TOWERSANDPODIUMS.CO.UK



DOC NO: OM001, VERSION:1.4, DATE:01/03/2024, APPROVED BY:A.GUNTRIPP, REVIEWED BY:M.GRANGER